



Go everywhere...

- High precision driving & smoothness
- Quick machine
- Comfort & agility
- Indoor / outdoor rated (Versatile)
- Easy access to the platform
- Smart transportability & lifting

... With the best value for money

- Robust machine
- Smart mast system
- Minimal maintenance & downtime
- Direct electric drive with brushless AC motors
- Easy access to components
- Haulotte Activ'Screen (onboard diagnostic)



STAR 6

VERTICAL MASTS

TECHNICAL DATA

STAR 6

| | |
|--------------------------------|-------------------|
| Working height | 5.8 m |
| Platform height | 3.8 m |
| Lift capacity | 230 kg |
| Platform size | 0.77 x 1.38 m |
| A Length | 1.4 m |
| B Width | 0.79 m |
| C Height - stowed | 1.75 m |
| D Wheelbase | 1.06 m |
| E Ground clearance | 6 cm |
| Drive speed proportional | 0.8 - 4.5 km/h |
| Turning radius - outside | 1.7 m |
| Tilt alarm | 1.5 ° / 3 ° |
| Gradeability | 25 % |
| Driveable at full height up to | 3.8 m |
| Hydraulic system capacity | 5 l |
| Tires - non marking | 308 x 108 |
| Power source | 12V - 105 Ah (C5) |
| Weight | 835 kg |

STANDARD EQUIPMENT

- 24 V electric drive brushless AC motors
- 12 V - 105 Ah traction batteries
- 20 A battery charger
- Battery charge indicator
- Haulotte ACTIV'Screen
- Fork lifting eyes
- Hoisting and lifting eyes
- Swing door entry gate
- Mobile potholes
- 2 drive speed
- 2 front steering wheels
- 2 rear driving wheels
- Non marking tires
- Brake release
- Hourmeter
- Horn
- Travel alarm
- Emergency stop
- Emergency hand pump
- 2 control stations at cage and ground level
- Mobile upper control box
- 2 towing hooks
- Walkable protection plinth

OPTIONS AND ACCESSORIES

- Platform extension deck +0.4 m
- Flashing light
- Power line in platform
- Ground-fault circuit interrupter 30 mA
- Hydraulic oil for cold countries
- Biodegradable oil
- Upper control box protection cover
- Fluorescent tube caddy
- Tool tray
- Maintenance-free batteries

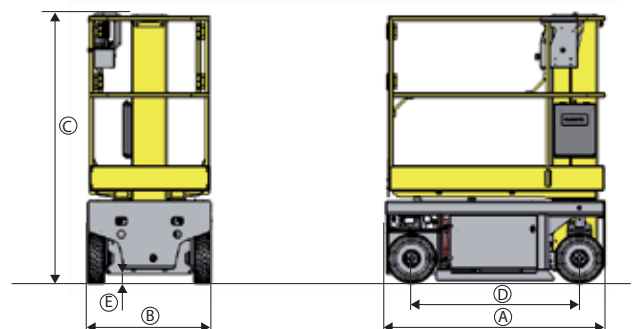
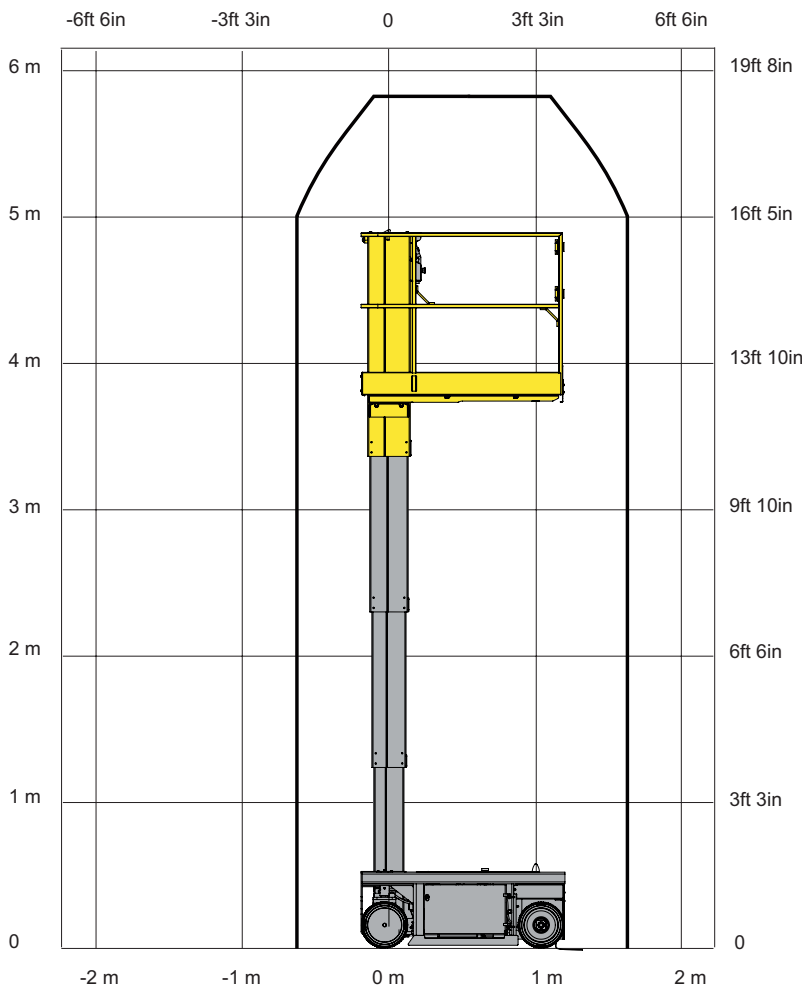

xxxxxxxx - Non contractual document - We reserve the right to modify the technical characteristics of this document without notice - 10/2015

