

## 41AM

### VERTICAL PERSONNEL LIFTS

## Platform

- 0.66 m x 0.66 m (W x L) Slide bar side entry platform
- Quick-change platform mounts
- Safety interlocked controls
- Load sensing system
- Lanyard attach points
- AC power cable to platform

## Power & Transmission

- 6 wheel chassis with 'X' pattern outriggers
- Outrigger interlocks with LED indicators
- Non mark tyres and casters
- Roller loading device

## Functional Equipment & Accessories

- Low maintenance anodised aluminium mast
- Spring loaded sequence cables
- Manual descent
- Key lock main power switch
- Hour meter
- Transportation tie-down lugs
- Fork truck pockets

## Available Options

- 0.56 m x 0.64 m (W x L) Narrow slide bar entry platform
- 110V or 230V mains power operation (AC models)
- 12V 100 A/hr deep cycle battery operation (DC models)
- Sealed 12V 100A/hr maintenance free AGM battery <sup>1</sup>
- Detachable battery & charger compartment <sup>2</sup>
- 20 amp automatic battery charger <sup>2</sup>
- Straddle extension kit with 1.09 m clearance
- Straddle extension kit with 1.40 m clearance
- Battery condition indicator <sup>2</sup>
- Programmable 4 digit security lock
- Lifting eye for crane hook
- Fluorescent tube caddy
- Tool tray (0.20 m x 0.46 m x 0.13 m)
- Descent alarm
- Emergency lowering control
- Amber strobe light

<sup>1</sup> Includes 5 hour battery charger

<sup>2</sup> Applicable to battery powered DC models only

# 41AM VERTICAL PERSONNEL LIFTS

Platform Height	12.42 m
Working Height	14.42 m
Platform Capacity	135 kg
Platform Size – Narrow (W x L)	0.56 m x 0.63 m
Platform Size – Side Entry (W x L)	0.66 m x 0.66 m
Overall Height – Stowed	2.64 m
Overall Height – Tilted Back	1.96 m
A. Base Width – Stowed	0.74 m
Base Length – Stowed	1.46 m
Base Length – Without Platform	1.35 m
Overall Length – Tilted Back	2.74 m
Ground Entry Height	0.48 m
Outrigger Footprint Length	2.13 m
Outrigger Footprint Width	2.18 m
Distance to Wall – Front	0.34 m
Distance to Wall – Side	0.75 m
Machine weight – AC *	485 kg
Machine weight – DC *	520 kg
Rear Wheel Diameter	25 cm
Caster Wheel Diameter	15 cm

\* Certain options or country standards may increase weight and/or dimensions.

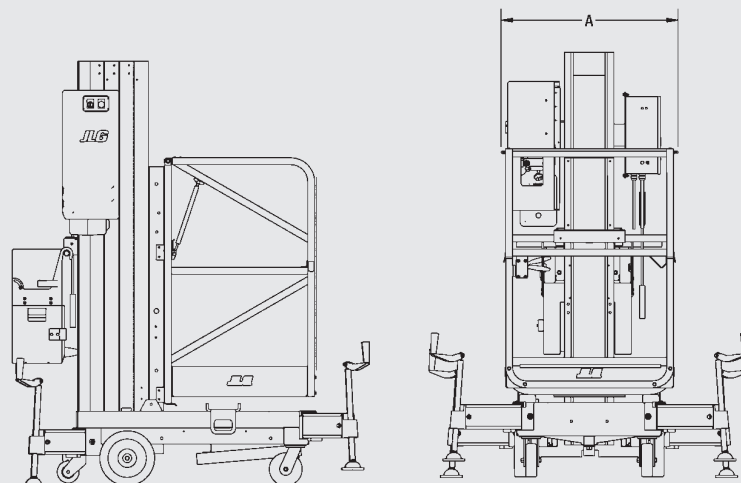
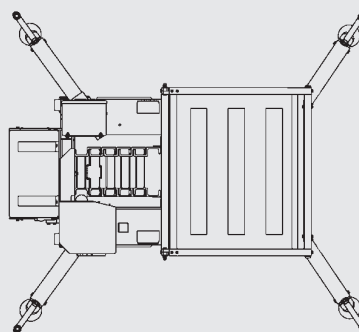

**JLG Industries, Inc. is a leading designer and manufacturer of access equipment and complementary services and attachments.**

JLG has manufacturing facilities in the United States, France, Romania, China and Belgium. Customers throughout Europe, Scandinavia, Africa and the Middle East benefit from a network of dedicated sales and service operations designed to deliver the highest levels of support.

**JLG is an Oshkosh Corporation company.**

[www.jlgeurope.com](http://www.jlgeurope.com)

JLG is continually researching and developing products and reserves the right to make modifications without prior notice. All data in this document is indicative. Certain options or country standards will increase weight. Specifications may change to meet country standards or with the addition of optional equipment.