

## **TOUCAN DUO** VERTICAL PERSONNEL LIFTS

### **Platform**

- 0.75 m x 0.65 m (W x L)  
Operator platform with double side entry
- 0.75 m x 0.50 m (W x L) Powered material tray
- Safety interlocked controls
- Full proportional drive joystick control with integral thumb steer switch
- Dedicated material tray controls
- Lanyard attachment anchor

### **Power & Transmission**

- 4 x 6Volt, 180 A/Hr deep cycle batteries
- Automatic dual voltage high frequency battery charger
- Battery condition indicator on platform
- Direct electric two wheel drive
- Brushless AC drive motors
- Brake release

### **Functional Equipment & Accessories**

- Low maintenance non-rotating extruded aluminium mast
- Passive pothole protection system
- Non marking solid rubber tyres
- 0.78 m wide frame
- Manual Descent
- 2 degree Tilt indicator and alarm
- Key lock main power switch
- Hour meter
- Transportation tie-down points
- Lifting eye for crane hook
- Fork truck lift points
- Horn
- Descent alarm
- Xenon strobe lights
- Food compatible lubrication and hydraulic oil

### **Available Options**

- Battery discharge indicator with low charge function cut-out
- 220A/hr maintenance free AGM batteries in lieu of standard
- Low temperature lubrication



# TOUCAN DUO

## VERTICAL PERSONNEL LIFTS

Working Height	6.00 m
Platform Height	4.00 m
Platform Capacity <sup>1</sup>	130 kg
Elevating Shelf Capacity	70 kg
A1. Platform Size (L x W)	0.65 m / 0.75 m
A2. Elevating Shelf Size (L x W)	0.50 m / 0.75 m
B. Overall Width	0.78 m
C. Stowed Height	1.79 m
D. Overall Length	1.65 m
E. Wheelbase	1.35 m
F. Ground Clearance	8 cm
Chassis Width	0.78 m
Machine weight *	1,000 kg
Maximum Ground Bearing Pressure	13.10 kg/cm <sup>2</sup>
Drive Speed - Lowered	4 km/h
Drive Speed - Elevated	1 km/h
Turning Radius (outside)	1.64 m
Turning Radius (inside)	0.00 m
Gradeability	20%
Tyres (non-marking solid)	300 x 80
Electrical system	24V DC
Batteries	24V - 180 A/hr
Dual Voltage 110/240V Charger	24V - 15A
Drive motors	2 motors 24V AC - 320 W
Brakes	Electromagnetic
Electrical motor	1 kW
Hydraulic system	6 L

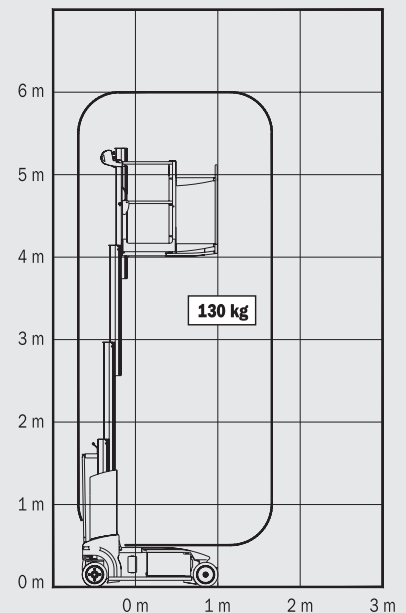

**JLG Industries, Inc. is a leading designer and manufacturer of access equipment and complementary services and attachments.**

JLG has manufacturing facilities in the United States, France, Romania, China and Belgium. Customers throughout Europe, Scandinavia, Africa and the Middle East benefit from a network of dedicated sales and service operations designed to deliver the highest levels of support.

**JLG is an Oshkosh Corporation company.**

[www.jlgeurope.com](http://www.jlgeurope.com)

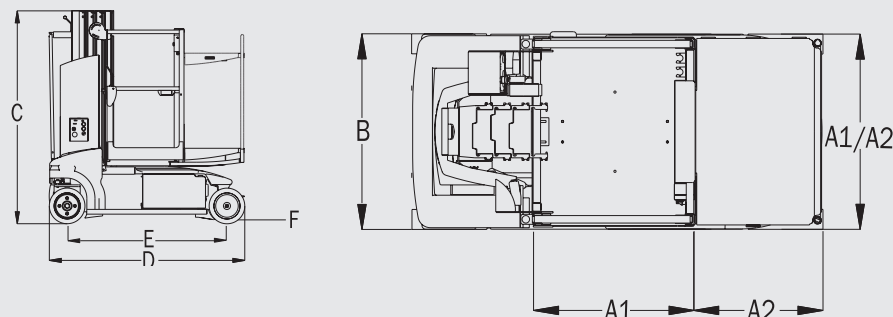

<sup>1</sup> Capacities shown are for 1 person indoors only

\* Certain options or country standards may increase weight and/or dimensions.