

ZOOMLION

ARTICULATING BOOM LIFT

ZA16J

Comply with CE/ANSI/CSA Standard

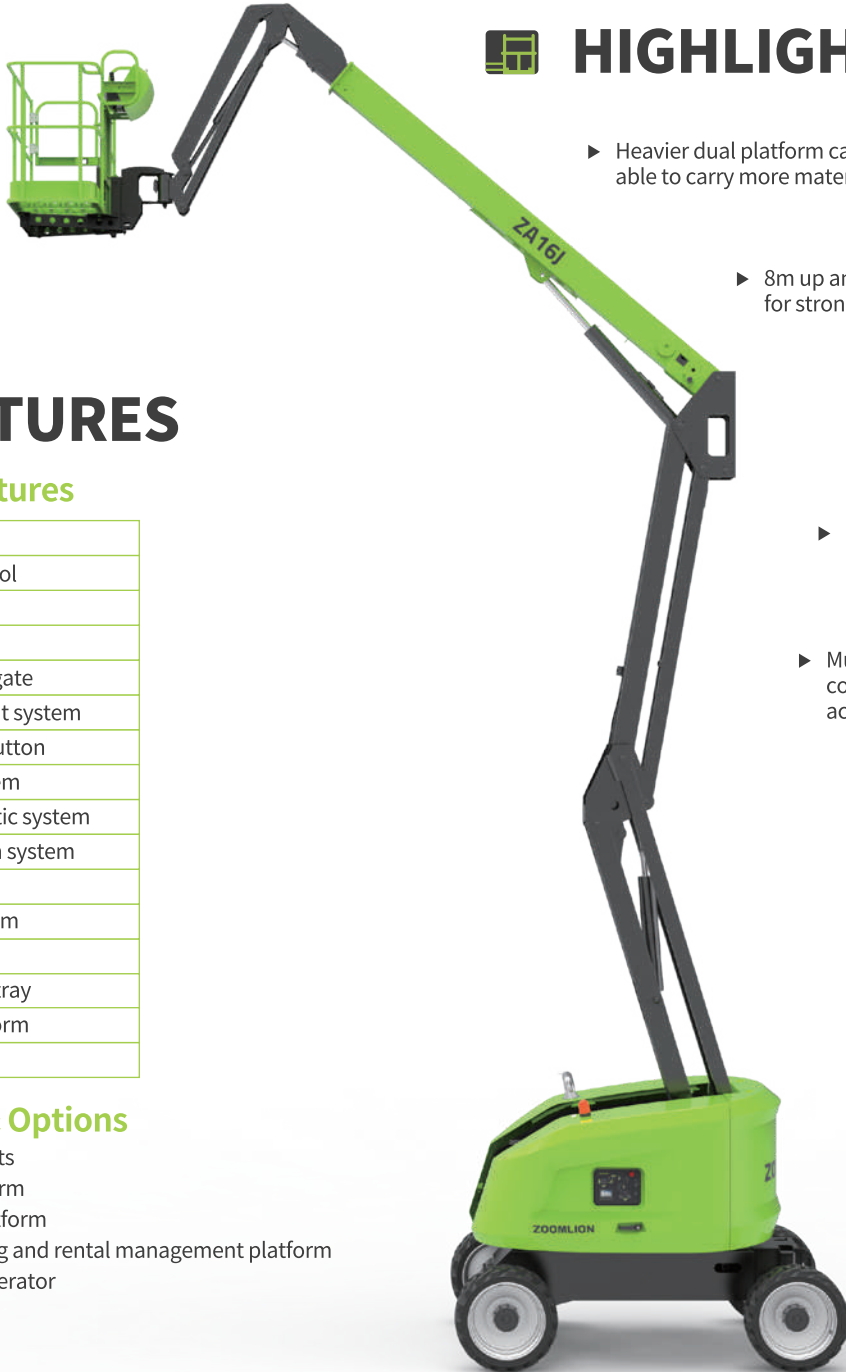

HIGHLIGHTS

- ▶ Heavier dual platform capacity of 250kg/360kg, able to carry more materials and tools
- ▶ 8m up and over height and outreach of 9.97m for strong obstacle-cross ability
- ▶ 360° continuous turntable rotation for flexible operation
- ▶ Symmetric boom layout with good boom stiffness for stable movement
- ▶ Multi-way valve control, pressure compensation function, smooth and accurate control



FEATURES

Standard Features

Horn
Proportional control
All motion alarm
Flashing beacon
Self-closing entry gate
Emergency descent system
Emergency stop button
Auto-leveling system
On-board diagnostic system
Over tilt protection system
Oscillating axle
Load sensing system
4.3' LED display
Swing-out engine tray
1.83×0.76m platform
GPS

Accessories & Options

- ▶ Platform work lights
- ▶ AC power to platform
- ▶ Airway tube to platform
- ▶ Remote monitoring and rental management platform
- ▶ 3kw Hydraulic generator

ACCESS WITH ZOOMLION GREEN



MAIN SPECS OF ARTICULATING BOOM LIFT

ZA16J

Comply with CE/ANSI/CSA Standard

Model	ZA16J	
	Imperial	Metric
Size		
Work Height	59ft 1in	18m
Platform Height	52ft 6in	16m
Horizontal Outreach	32ft 9in	9.97m
Up and Over Height	26ft 3in	8m
A - Stowed Length	26ft 1in	7.95m
B - Stowed Width	7ft 6in	2.27m
C - Stowed Height	7ft 4in	2.23m
D - Platform Length	6ft 1in	1.83m
E - Platform Width	2ft 6in	0.76m
F - Wheelbase	7ft 9in	2.36m
G - Ground Clearance	1ft 5in	0.42m
Performance		
Platform Capacity	550lbs/793lbs	250 kg/360 kg
Drive Speed	3.73mph	6km/h
Gradeability	45%(24°)	45%(24°)
Axles Oscillation	4in	0.1m
Turning Radius (Inside)	6ft 10in	2.06m
Turning Radius (Outside)	15ft 9in	4.78m
Turntable Swing	360°continuous	
Platform Rotation	±90°	
H-Tail Swing	0m	
Max. Working Slope	5°	
Max. Wind Speed	7.77mph	12.5m/s
Power		
Diesel Engine	Kubota V2403(EU V) 36.8kw/2700rpm Kubota V2403(CN III) 36kw/2600rpm	
Fuel Tank Capacity	33 (gal)	150L
Auxiliary Power	12V	
Control Voltage	12V	
Hydraulic System Capacity	24.2(gal)	110L
Hydraulic Tank Capacity	17.6 (gal)	80L
Tire		
Type	Foam-filled tire	
Weight		
Gross	18849lb	8550kg

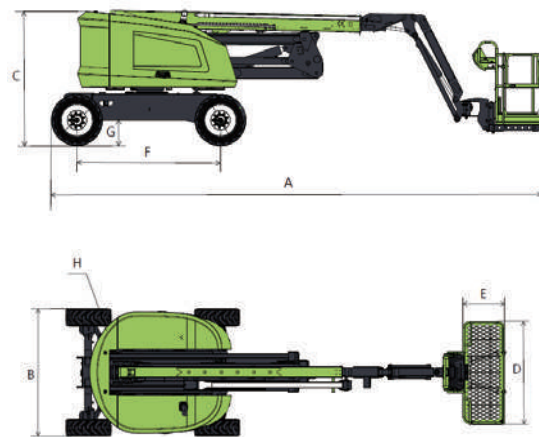

Max Work Height 18 m / 59ft 1in
Max Outreach 9.97 m / 32ft 9in

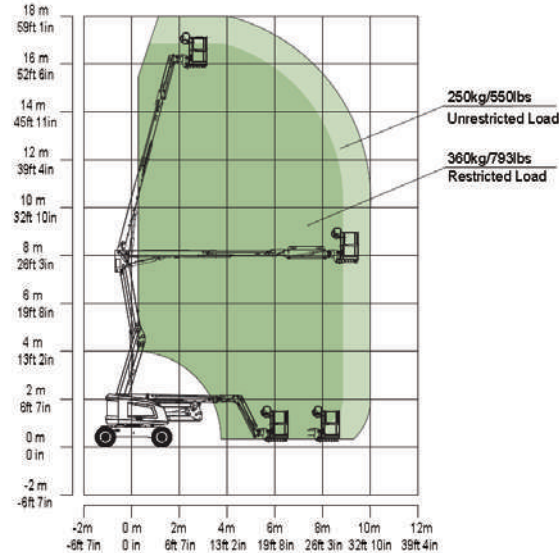

Range of Motion ZA16J

AJ Access Platforms Ltd, Pill Way, Severn Bridge Industrial Estate,
Caldicot Monmouthshire, NP26 5PU, UK
Phone: +44 (0) 1291 421 155
Email: info@accessplatforms.com, sales@accessplatforms.com
Web: www.accessplatforms.com

[Get Pricing](#)

