

ZOOMLION

ROUGH TERRAIN

ELECTRIC ARTICULATING BOOM LIFT

ZA16JERT/ZA16JERT-Li

Comply with CE/ANSI/CSA Standard

FEATURES

Standard Features

- Proportional control
- All motion alarm
- Flashing beacon
- Self-closing entry gate
- Emergency descent system
- Emergency stop button
- Auto-leveling system
- On-board diagnostic system
- Over tilt protection system
- Oscillating axle
- Load sensing system
- Battery management system
- 4.3' LED display
- Horn
- Anti-crushing device

Accessories & Options

- Platform light
- AC power to platform
- Non-marking tire
- GPS
- Platform mesh to Mid or Top rail
- Storage Tray
- White Noise Alarm

HIGHLIGHTS

- ▶ Center layout, great structural rigidity, and small boom deflection
- ▶ Accurate and efficient traveling AC drive system provides strong power and stable control, motor maintenance-free
- ▶ Electrical off-road articulating boom lift of 16m height with strong power suits for complicated working conditions
- ▶ 4WD provides strong power, ideal for off-road application
- ▶ Advanced dual control system (valve control + pump control) offers a energy-saving, smooth and efficient control
- ▶ Large-capacity lithium battery features long-lasting battery life, and number of charge and discharge cycles reaches 2500 times, the whole life cycle is maintenance-free, and a 5-year warranty is provided(ZA16-JERT-Li only)

ACCESS WITH ZOOMLION GREEN



Model	ZA16JERT/ZA16JERT-Li	
	Imperial	Metric
Size		
Work Height	58ft 5in	17.8m
Platform Height	51ft 10in	15.8m
Horizontal Outreach	31ft 11in	9.72m
Up and Over Height	26ft 3in	8m
A - Stowed Length	25ft 3in	7.7m
B - Stowed Width	7ft 6in	2.3m
C - Stowed Height	7ft 4in	2.23m
D - Platform Length	6ft	1.83m
E - Platform Width	2ft 6in	0.76m
F - Wheelbase	7ft 9in	2.36m
G - Ground Clearance	1ft 2in	0.36m
Performance		
Platform Capacity	550 lb	250kg
Drive Speed	3.2 mph	5.2km/h
Gradeability	45%(24°)	
Axles Oscillation	8in	0.20m
Turning Radius (Inside)	6ft 9in	2.06m
Turning Radius (Outside)	15ft 8in	4.78m
Turntable Swing	360° non-continuous	
Platform Rotation	±90°	
H-Tail Swing	0.6ft	0.2m
Max. Working Slope	5°	
Max. Wind Speed	28mph	12.5m/s
Power		
Battery	24×2V/375Ah 48V/315Ah Li-ion battery	
Charger	48V/60A	
Drive Motor	AC 32V	
Lift Motor	AC 32V	
Auxiliary Power	12V DC Electrical pump	
Hydraulic Tank Capacity	7.9 (us gal)	30L
Tire		
Type	33×12 Foam-filled tire	
Weight		
Gross	16093 lb	7300 kg

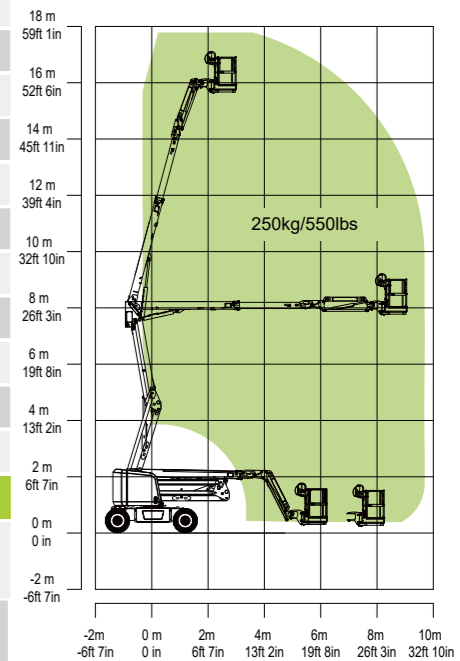
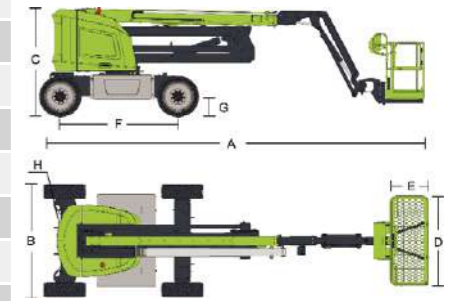

Range of Motion ZA16JERT/ZA16JERT-Li

AJ Access Platforms Ltd, Pill Way, Severn Bridge Industrial Estate,
Caldicot Monmouthshire, NP26 5PU, UK
Phone: +44 (0) 1291 421 155
Email: info@accessplatforms.com, sales@accessplatforms.com
Web: www.accessplatforms.com

Get Pricing

