

ZOOMLION

ARTICULATING BOOM LIFT

ZA20J

Comply with ANSI/CSA Standard



HIGHLIGHTS

- ▶ 250/360kg platform capacity for higher efficiency
- ▶ Build-in multiple pressure control leveling system to enhance stability
- ▶ Precise load sensing system to improve overload safety operations
- ▶ Integrated with rotary reducer to enhance rotation stability
- ▶ Hostile Kits available for dusty working environment
- ▶ Deadweight Lowering System for smooth operation and energy efficiency
- ▶ Platform fast lifting function provides high-efficient performance without tower boom operation
- ▶ Lightweight design, low energy consumption

FEATURES

Standard Features

| |
|-----------------------------|
| Horn |
| All motion alarm |
| Proportional control |
| Self-closing entry gate |
| Flashing beacon |
| Auto-leveling system |
| Emergency stop button |
| Over tilt protection system |
| Emergency descent system |
| On-board diagnostic system |
| Oscillating axle |
| 4.3' LED display |
| Load sensing system |
| Swing-out engine tray |
| Anti-crushing device |

Accessories & Options

- ▶ Platform work lights
- ▶ AC power to platform
- ▶ GPS
- ▶ Non-marking tire
- ▶ 3kw Hydraulic generator
- ▶ Platform mesh to Mid or Top rail
- ▶ Fall Arrest, Rear Entry
- ▶ Storage Tray
- ▶ Welder Ready Package
- ▶ White Noise Alarm

ACCESS WITH ZOOMLION GREEN



| Model | ZA20J | |
|---------------------------|------------------------------|-------------|
| | Imperial | Metric |
| Size | | |
| Work Height | 70ft 1in | 21.38m |
| Platform Height | 63ft 7in | 19.38m |
| Horizontal Outreach | 40ft 4in | 12.3m |
| Up and Over Height | 27ft 1in | 8.25m |
| A - Stowed Length | 28ft 11in | 8.82m |
| B-Stowed Width | 8ft 1in | 2.46m |
| C-Stowed Height | 8ft 4in | 2.52m |
| D-Platform Length | 8ft | 2.44m |
| E-Platform Width | 3ft | 0.91m |
| Jib Length | 5ft | 1.53m |
| F-Wheelbase | 8ft 3in | 2.52m |
| G-Ground Clearance | 1ft 5in | 0.42m |
| Performance | | |
| Platform Capacity | 550 lb/793 lb | 250kg/360kg |
| Drive Speed | 3.79 mph | 6.1km/h |
| Gradeability | 45%(24°) | |
| Axles Oscillation | 8in | 0.2m |
| Turning Radius (inside) | 8ft 3in | 2.51m |
| Turning Radius (Outside) | 17ft 11in | 5.47m |
| Turntable Swing | 360° continuous | |
| Platform Rotation | ±90° | |
| H-Tail Swing | 1ft 4in | 0.4m |
| Max. Wind Speed | 28mph | 12.5m/s |
| Power | | |
| Diesel Engine | Kubota V2403 | |
| Fuel Tank Capacity | 39.6 (us gal) | 150L |
| Auxiliary Power | 12V | |
| Control Voltage | 12V | |
| Hydraulic System Capacity | 42.3 (us gal) | 160L |
| Hydraulic Tank Capacity | 19.8 (us gal) | 75L |
| Tire | | |
| Type | 33×12/D610 Foam-filled Tires | |
| Weight | | |
| Gross | 22046 lb | 10000kg |

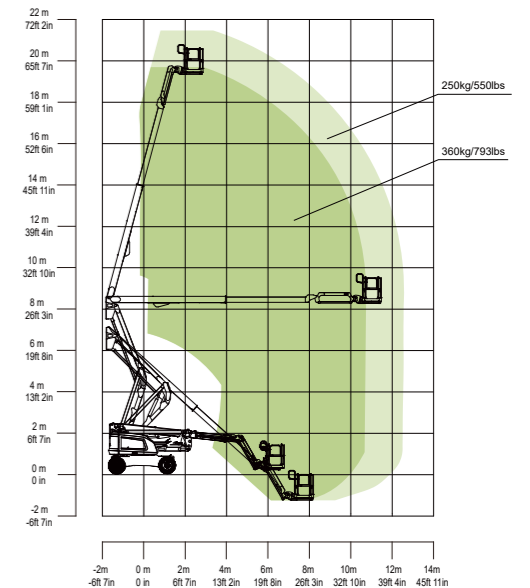
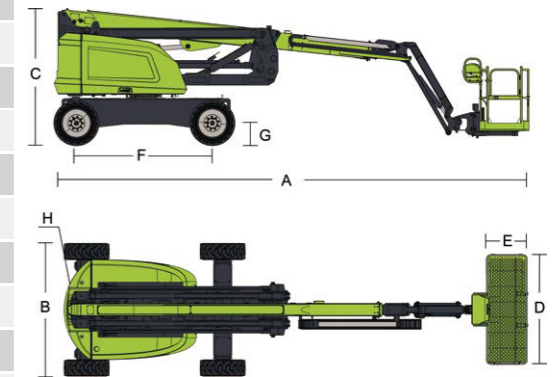

Range of Motion ZA20J

AJ Access Platforms Ltd, Pill Way, Severn Bridge Industrial Estate,
 Caldicot Monmouthshire, NP26 5PU, UK
 Phone: +44 (0) 1291 421 155
 Email: info@accessplatforms.com, sales@accessplatforms.com
 Web: www.accessplatforms.com

[Get Pricing](#)

