

# ZOOMLION

## VERTICAL MAST LIFTS

### ZMP04/ZMP06

#### HIGHLIGHTS

- ▶ Permanent magnet synchronous traveling motor, energy saving and high efficiency
- ▶ Standard large-diameter tires and collectable pothole plates, easy to pass the threshold
- ▶ Front wheel driving and steering and small turning radius for flexible indoor movement
- ▶ Multi-arm synchronous lifting, fast and no impact
- ▶ Compact dimensions, access to lifts, and ideal for indoor applications

#### FEATURES

##### Standard Features

Autobrake system	Emergency stop button
Proportional control	Flashing beacon
All motion alarm	Active pothole protection system
Charging protection system	Horn
Self-closing entry gate	On-board diagnostic
Maintenance-free battery	Hour meter
Unidirectional extension platform	Load sensing system
Drivable at full height	Over tilt protective system
Emergency descent system	Forklift pockets

##### Accessories & Options

- ▶ Platform work light
- ▶ AC power to platform
- ▶ GPS



ACCESS WITH ZOOMLION GREEN



Model	ZMP04	ZMP06
<b>Size</b>		
Work height	5.82m	7.91m
A - Platform Height-Elevated	3.82m	5.91m
B - Platform Height-Stowed	0.6m	0.74m
C - Platform Length	1.02m	1.02m
D - Platform Width	0.76m	0.76m
K-Platform Extension	0.5m	0.5m
E - Overall Height	1.72m	1.99m
F - Overall Length	1.39m	1.39m
G - Overall Width	0.78m	0.78m
H - Wheelbase	1.06m	1.06m
I - Ground Clearance (Stowed)	0.065m	0.065m
J - Ground Clearance (Raised)	0.017m	0.017m
<b>Performance</b>		
Platform Capacity	230kg	200kg
Capacity on Deck Extension	113kg	113kg
Max. Number of Workers (indoor/outdoor)	2/1	1/0
Drive Speed (Stowed)	4km/h	4km/h
Drive Speed (Raised)	0.5km/h	0.5km/h
Turning Radius (Inside)	0.14m	0.14m
Turning Radius (Outside)	1.43m	1.43m
Lifting Motor	24V/2.5KW	24V/2.5KW
Drive Motor	24V/2×0.6KW	24V/2×0.6KW
Up/Down Time	18/21s	27/30s
Gradeability	25% (14°)	25% (14°)
Max. Working Slope (Lateral/Vertical)	1.5°/3°	1.5°/3°
Control	Proportional control	Proportional control
Drive	Front wheels	Front wheels
Brake	Front wheels	Front wheels
Tire	Solid seamless tire	Solid seamless tire
<b>Power</b>		
Battery	120Ah	120Ah
Charger	24V/30A	24V/30A
<b>Weight</b>		
Gross	900kg	1085kg

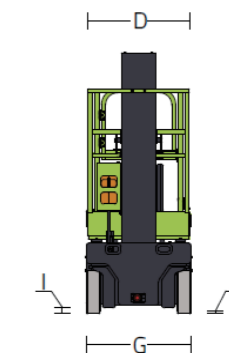
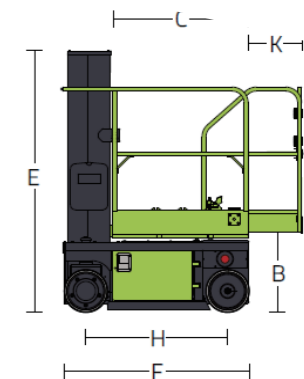
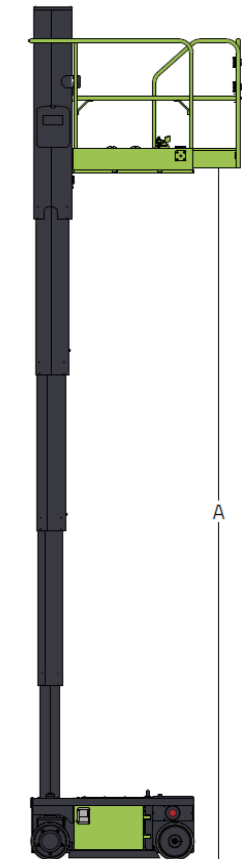

AJ Access Platforms Ltd, Pill Way, Severn Bridge Industrial Estate,  
 Caldicot Monmouthshire, NP26 5PU, UK  
 Phone: +44 (0) 1291 421 155  
 Email: info@accessplatforms.com, sales@accessplatforms.com  
 Web: www.accessplatforms.com

[Get Pricing](#)

