

# ZOOMLION

## EXTENDED-RANGE HYBRID TELESCOPIC BOOM LIFT

### ZT21JEH-V

Comply with CE Standard



#### HIGHLIGHTS

- ▶ 6kw large power range extender provides power in low electric quantity for long working hours
- ▶ New off-road chassis, gradeability of 45%, strong obstacle climbing ability
- ▶ Accurate and effective drive system, strong power, stable control, and motor maintenance free
- ▶ High frequency and low amplitude response control technology, click to move with buffer
- ▶ Compact design and folded jib for wrecker and container transportation
- ▶ Parallel four link and three telescopic boom sections for dynamic CG adjustment and compact structure
- ▶ Controller remote upgrade and mobile parameter adjustment for high service efficiency
- ▶ Load-sensitive and engine condition matching energy-saving technology, as well as the boom self-weight lowering function, energy consumption reduced by 18% compared to conventional technology

#### FEATURES

##### Standard Features

Telecommunications System
Horn
Proportional control
All motion alarm
Flashing beacon
Self-closing entry gate
Emergency descent system
Emergency stop button
Auto-leveling system
On-board diagnostic system
Tilt protection system
Oscillating axle
Load sensing system
Remote monitoring and rental management platform

##### Accessories & Options

- ▶ Platform work light
- ▶ Anti-collision device
- ▶ AC power to platform

ACCESS WITH ZOOMLION GREEN



Model	ZT21JEH-V
<b>Size</b>	
Work Height	22.95m
Platform Height	20.95m
Horizontal Outreach	15.5m
A Overall Length (Stowed)	9.4m (6.8m)
B Overall Width (Stowed)	2.46m
C Overall Height (Stowed)	2.7m
D Platform Length	2.44m
E Platform Width	0.91m
F Wheelbase	2.52m
Track width	2.46m
G Ground Clearance	0.33m
<b>Performance</b>	
Platform Capacity	300/454kg
Drive Speed (stowed)	5.2km/h
Gradeability	45%(24°)
Turning Radius (Inside)	2.69m
Turning Radius (Outside)	5.45m
Turntable Rotation	360° continuous
Platform Rotation	±90°
Tail Swing	1.7m
Jib Rotation	130° (-55°~75°)
Max. Wind Speed	12.5m/s
<b>Power</b>	
Battery	51.2V/315Ah
Range Extender	6kW
Charger	48V / 60A
Drive Motor	3.3kW
Lift Motor	10kW
Auxiliary power	12V DC
Fuel Tank	105L
Hydraulic Tank Capacity	75L
<b>Tire</b>	
Tire Type	Foam-filled tire
<b>Weight</b>	
Gross	10600kg

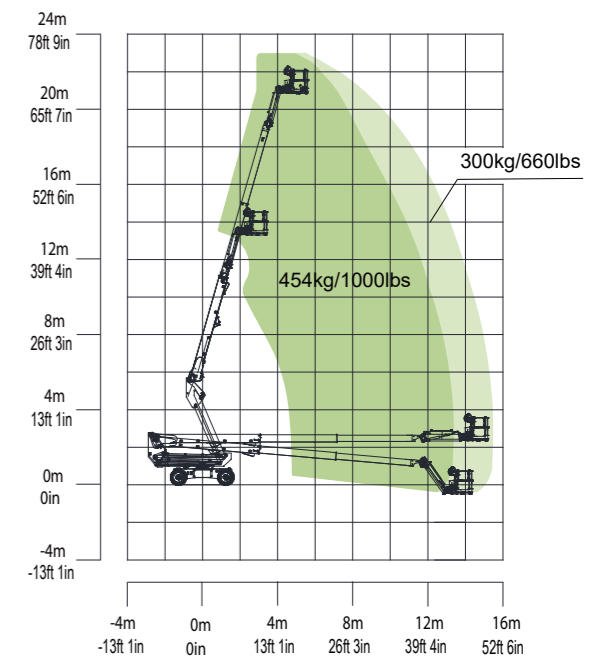
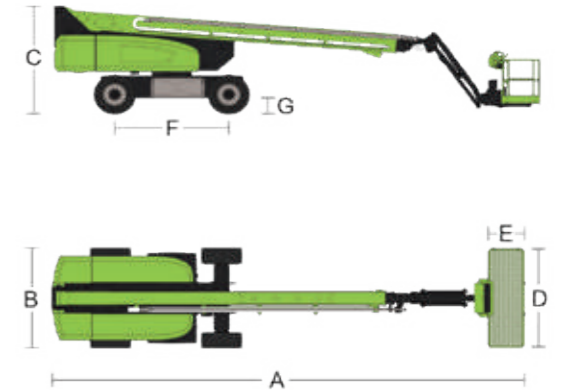

Range of Motion ZT21JEH-V

AJ Access Platforms Ltd, Pill Way, Severn Bridge Industrial Estate,  
Caldicot Monmouthshire, NP26 5PU, UK  
Phone: +44 (0) 1291 421 155  
Email: info@accessplatforms.com, sales@accessplatforms.com  
Web: www.accessplatforms.com

[Get Pricing](#)

