

Genie® GS™ -4655

Specifications

Models	GS-4655 E-Drive	
Measurements	US	Metric
Working height max. - indoor ⁽¹⁾	51 ft 9 in	15.95 m
Working height max. - outdoor ⁽¹⁾	27 ft 6 in	8.55 m
A Platform height max. - indoor	45 ft 9 in	13.95 m
A Platform height max. - outdoor	21 ft 6 in	6.55 m
B Platform height - stowed	5 ft 5 in	1.64 m
C Platform length - outside	9 ft 4 in	2.84 m
C Platform length - outside, extended	13 ft 4 in	4.10 m
Slide-out platform extension deck - length	4 ft	1.22 m
D Platform width - outside	4 ft 5 in	1.35 m
Guardrail height	3 ft 7.3 in	1.10 m
Toeboard height	6 in	15 cm
E Height - stowed (folding rails)	9 ft 1 in	2.77 m
E Height - stowed (rails lowered)	6 ft 6 in	1.98 m
F Length machine - stowed	10 ft 2 in	3.11 m
F Length machine - stowed, extended	14 ft 2 in	4.33 m
G Width	55.3 in	1.41 m
H Wheelbase	8 ft 1 in	2.47 m
I Ground clearance (center) - pothole guards retracted	5.9 in	15 cm
I Ground clearance - pothole guards deployed	0.75 in	2 cm

Productivity

Maximum platform occupancy (in/out)	3/2	3/2
Lift capacity	770 lb	350 kg
Lift capacity - extension deck extended	300 lb	136 kg
Max. platform drive height	45 ft 9 in	13.95 m
Drive speed - stowed	2.5 mph	4.0 km/h
Drive speed - raised	0.5 mph	0.8 km/h
Gradeability - stowed ⁽²⁾	25%	25%
Turning radius - inside/outside	12 in/ 10 ft	31 cm/ 3.05 m
Lifting speed - raise/lower	92/ 58 sec	92/ 58 sec
Tilt sensor activation (front to back/side to side)	3°/1.5°	3°/1.5°
Tires - solid non-marking	15x5 in	38x13 cm

Power

Power	24 V DC (4 x 12 V 300 Ah)	24 V DC (4 x 12 V 300 Ah)
Hydraulic tank capacity (E-Drive)	7.5 gal	28.4 L

Weight⁽³⁾ and Floor Loading⁽⁴⁾

Weight	8,160 lb	3,701 kg
Tire load max.	3,682 lb	1,670 kg
Tire contact pressure	210 psi	1,451 kPa
Occupied floor pressure	205 psf	9.81 kPa

Sound and Vibration Levels

Sound Pressure level (ground workstation)	< 70 dBA	< 70 dBA
Sound Pressure level (platform workstation)	< 70 dBA	< 70 dBA
Vibrations	< 2.5 m/s ²	< 2.5 m/s ²

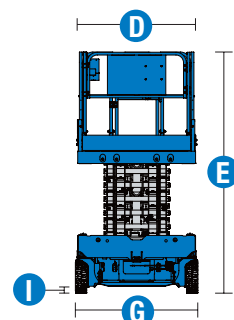
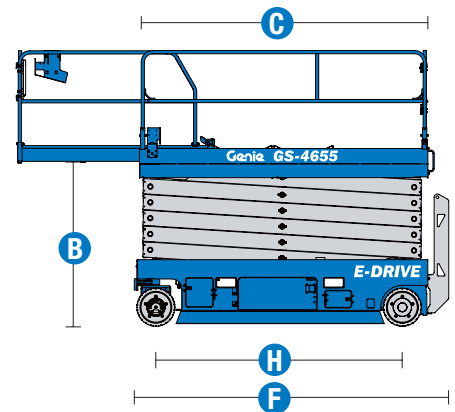
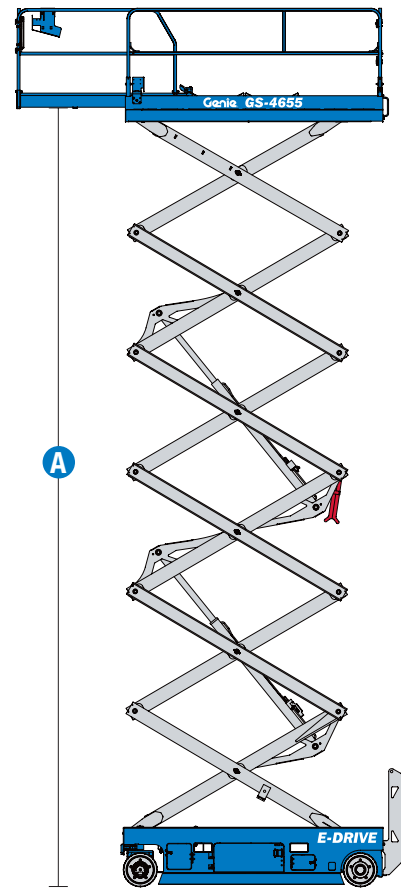

(1) The metric equivalent of working height adds 2 m to platform height. US adds 6 ft to platform height.

(2) Gradeability applies to driving on slopes and may vary depending on options and machine configurations. See operator's manual for details regarding slope ratings.

(3) Weight refers to standard configuration and may vary depending on options and/or country standards.

(4) Floor loading information is approximate and may vary depending on options and machine configurations. It should be used only with adequate safety factors.

Genie® GS™ -4655

Models

- GS-4655, E-Drive

Option availability		S	S+	BtO
Power	AGM Maintenance-free batteries			○
	Rear recessed charger receptacle	✓	✓	✓
Platform	Power to platform with RCBO		○	○
	Power to platform, no RCBO	✓	✓	✓
	Air line to platform			○
	Automotive-style horn		○	○
	Lift Tools Work Tray		○	○
	AC power to platform	✓	✓	✓
	Descent, tilt and motion alarm	✓	✓	✓
	Diamond plate platform	✓	✓	✓
	Dual LED flashing beacons	✓	✓	✓
	Electric horn	✓	✓	✓
	Folding rails, Full-height swing gate	✓	✓	✓
	Lanyard attachment points	✓	✓	✓
	Platform control guard	✓	✓	✓
	Platform load sense system	✓	✓	✓
	Proportional drive and lift	✓	✓	✓
Slide out extension deck	✓	✓	✓	
SmartLink dual zone control system	✓	✓	✓	
Chassis	Lift Connect Telematics		○	○
	Lift Connect with Access Manager upgrade		○	○
	Eco32 biodegradable hydraulic oil		○	○
	Auxiliary platform lowering	✓	✓	✓
	Dual front wheel AC electric drive motors	✓	✓	✓
	Dual wheel multi-disc brakes	✓	✓	✓
	Electric brake release	✓	✓	✓
	Manual brake release	✓	✓	✓
	On board diagnostic system with battery indicator	✓	✓	✓
	Pothole protection	✓	✓	✓
	Side and rear fork pockets	✓	✓	✓
Solid non-marking tires	✓	✓	✓	
Tech Pro Link connector	✓	✓	✓	
Tie-down and lifting points	✓	✓	✓	

- S Standard
- S+ Standard +
- BtO Build to Order
- Options



Indoor & Outdoor Use



Max Lift Capacity



E-Drive

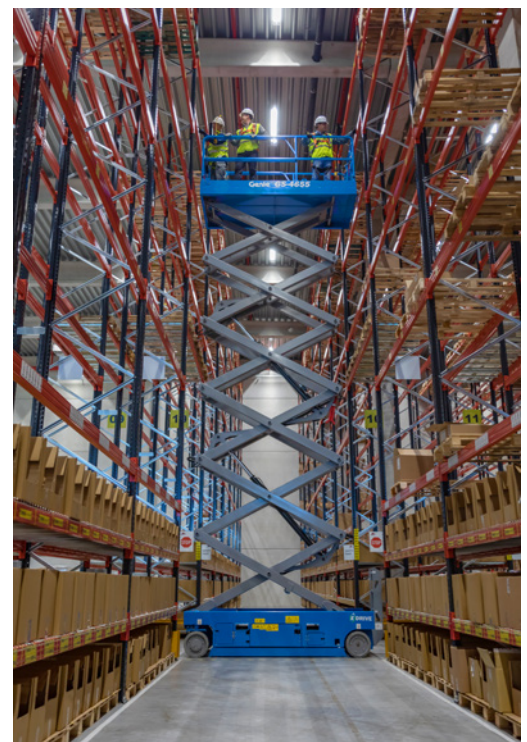

Genie Genuine Accessories⁽¹⁾

- Lift Tools Productivity Tools
- Lift Connect Telematics
- Tech Pro Link Handheld Device

(1) More accessories available from Genie Genuine Parts.



AJ Access Platforms Ltd

Pill Way, Severn Bridge Industrial Estate, Caldicot Monmouthshire, NP26 5PU, United Kingdom. Phone: +44 (0) 1291 421 155 Email: info@accessplatforms.com, sales@accessplatforms.com



© 2021 Terex Corporation

QUALITY BY DESIGN