

HA32 RTJ PRO



PERFORMANCE & EASE OF USE

- > Unrestricted working envelope with a max. 21.60 m horizontal outreach
- > Unmatched versatility
- > Outstanding rough terrain driving features: 4 wheel drive and steer, oscillating axle
- > Excellent time to full height of 95 sec. thanks to fully proportional controls and simultaneous boom functions

OPTIMIZED MAINTENANCE

- > Exclusive modular basket quick and easy to repair
- > Easy access to all components
- > Self-diagnosis tool integrated on the lower control box

BEST SAFETY FEELING

- > Haulotte Activ'Shield Bar 2.0
- > Most rigid boom



HA32 RTJ PRO

ROUGH TERRAIN ARTICULATING BOOMS

TECHNICAL DATA

HA32 RTJ PRO

Working height	31.8 m
Platform height	29.8 m
Horizontal outreach	21.6 m
Up and over clearance	11.35 m
Below ground reach	5.5 m
Lift capacity	250 kg (2 pers.)
F x G Platform size	2.44 x 0.91 m
A Length - stowed	11.7 m
B Width	2.53 m
H Storage / transport length	8.9 m
Storage / transport height	3.75 m
Width - with extended axles	3.3 m
C Height - stowed	2.8 m
Vertical jib rotation	140° (+ 70 / - 70)
Platform rotation	180° (+ 90 / - 90)
Turntable rotation	360° continuous
Tailswing	3.3 m
D Wheelbase	3.5 m
E Ground clearance	38 cm
Tilt	5 °
Drive speed	0.5 - 5 km/h
Maximum wind speed rating	60 km/h
Gradeability	40 %
Tyres - foam-filled	445 / 65-22.5
Turning radius - outside axle extended	5.74 m
Power source	Deutz, 55 kW, Turbo (Stage 5 in EU) ; Perkins, 62.5 kW, Turbo (Stage 3A in NRC)
Weight	20 100 kg

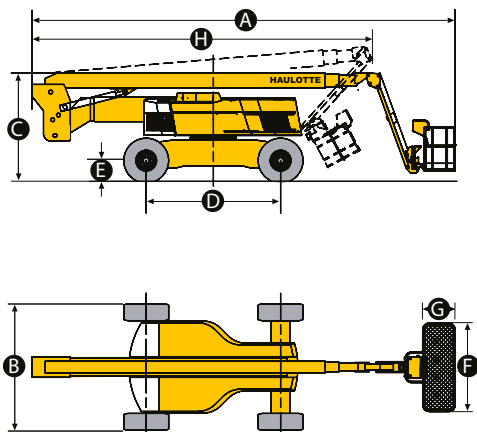

STANDARD EQUIPMENT

- > Haulotte Activ'Shield Bar 2.0
- > Universal telematics plug
- > 4 wheel drive and steer
- > Front oscillating axle increasing stability on uneven ground
- > 2 extendable axles
- > Proportional controls enhancing comfort and safety
- > 4 simultaneous movements for highest productivity
- > Differential wheel lock increasing rough terrain capacity
- > Upper control box protection cover and tool tray in plastic ultra-solid material
- > Modular large platform with drop bar entry gate
- > Power to platform 110 V / 220 V (Female plug in the basket)
- > Basket compensation $\pm 10^\circ$
- > Enhanced Swing out engine tray for ease of maintenance
- > Sound and light alarm for tilt and load
- > Driving beacon
- > Travel alarm
- > Hourmeter
- > Electric pump system and emergency descent
- > 12 V battery / electrical control system
- > Engine pre-heater with light indicator
- > Low fuel level indicator (upper control box)
- > Towing hooks

OPTIONS AND ACCESSORIES

- > Air line to platform
- > Lateral swing door gate
- > On-board hydraulic generator 3.5 kW
- > Biodegradable hydraulic oil
- > Hydraulic oil cooler
- > Hydraulic oil in tank and circuit for warm countries
- > Cap with key for diesel tank
- > Cold weather kit
- > Pipe cradle pack
- > Glazier Pack
- > Automatic Overspeed Air Shutdown Valve (electric one-way valve, flame arrestor, spark arrestor)
- > 55 W Platform working light

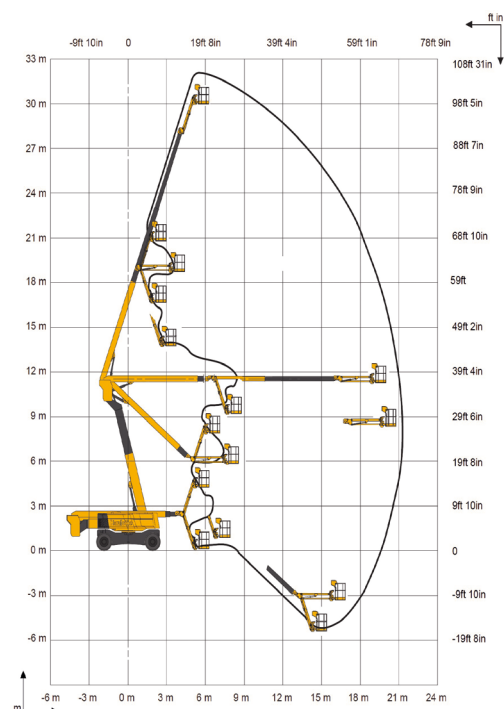

AJ Access Platforms Ltd

Pill Way, Severn Bridge Industrial Estate, Caldicot Monmouthshire, NP26 5PU, United Kingdom.
Phone: +44 (0) 1291 421 155 Email: info@accessplatforms.com, sales@accessplatforms.com



Haulotte
LET'S DARE TOGETHER