

HA16 RTJ / RTJ O



PERFORMANCE & EASE OF USE

- > Industry leading working envelope with an outreach of 8.3 m
- > Best lifting speed of 40 sec
- > Fully proportional and simultaneous movements

BEST COMFORT AND SAFETY FEELING

- > Haulotte Activ'Shield Bar 2.0 (option)
- > Haulotte Activ'Lighting System (option) for safe loading / unloading in conditions of low visibility

MINIMIZED TOTAL COST OF OWNERSHIP

- > Haulotte Activ'Screen (on board diagnostic)
- > Haulotte Stop Emission System: automatically turns the engine off & on
- > Easy access to all components
- > Fully modular basket with upper control box cover

HA16 RTJ / RTJ O

ROUGH TERRAIN
ARTICULATING BOOMS

TECHNICAL DATA

HA16 RTJ HA16 RTJ O

Working height	16 m
Platform height	14 m
Horizontal outreach	8.3 m
Up and over clearance	7.65 m
Lift capacity	230 kg (2 pers.)
F x G Platform size	1.83 x 0.80 m
A Length - stowed	6.75 m
H Storage / transport length	5.05 m
B Width	2.3 m
C Height - stowed	2.3 m
I Storage / transport height	2.4 m
Vertical jib rotation	140° (- 80° / + 60°)
Platform rotation	165° (- 75° / + 90°)
Turntable rotation	355° non continus
Tailswing	10 cm
D Wheelbase	2.1 m
E Ground clearance	38 cm
Tilt	5°
Drive speed	5.2 km/h
Gradeability	40 %
Turning radius - outside	4.5 m
Tyres - solid rough terrain	850 x 340 mm
Power source	Kubota, 18.5 kW (Stage 5 in EU) - Kubota, 26.5 kW, (Stage 3A in NRC)
Weight	6 200 kg 6450 kg

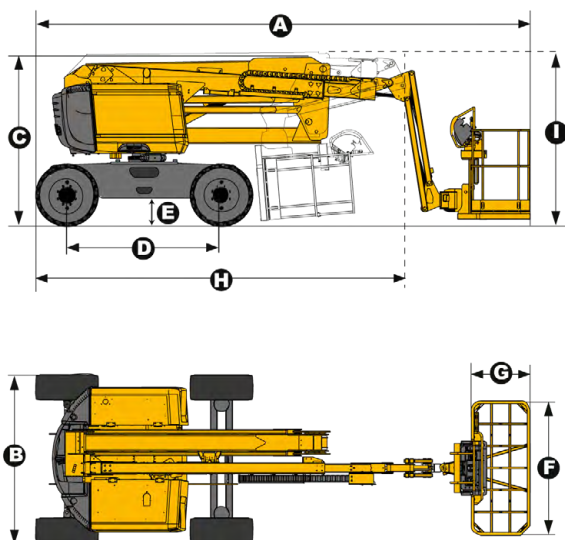

STANDARD EQUIPMENT

- > Haulotte Stop Emission System
- > Embedded diagnostic system Haulotte Activ'Screen on lower control box, with color screen.
- > Universal telematics plug
- > 4 wheel drive
- > 2 wheel steer
- > Front oscillating axle (RTJ O) increases stability on uneven ground
- > 4 simultaneous movements for maximum productivity
- > Permanent limited slip differential
- > Upper control box cover
- > Tool tray
- > 230 kg (2 persons) load capacity
- > Modular standard basket 1.83 m x 0.80 m, quick & easy to repair
- > Drop bar entry gate
- > AC power to platform (110 / 230 V)
- > Swing out engine tray for ease of maintenance
- > Sound and light alarm for tilt and load
- > Rotating beacon
- > Travel alarm
- > Hour meter
- > 12 V battery / electrical control system
- > Engine pre-heater with light indicator
- > Low fuel level indicator (upper & lower control boxes)
- > Electric pump system and emergency descent

OPTIONS AND ACCESSORIES

- > Haulotte Activ'Lighting System
- > Haulotte Activ'Shield Bar 2.0
- > Large cured on solid rough terrain tires 1025 x 365
- > Non-marking tires 14 x 17.5
- > Modular large basket 2.44 m x 0.91 m quick and easy to repair
- > Power to platform (female plug in the basket with or without circuit-breaker 30 mA)
- > Air-line to platform 6.5 mm inner diameter
- > Lateral swing door entry gate
- > Hydraulic generator Dynaset 3.5 Kw
- > Biodegradable hydraulic oil
- > Hot weather kit: hydraulic oil cooler + hydraulic oil
- > Cold weather kit: -10°C / - 25°C
- > Spark arrestor and electric one-way valve
- > Working light
- > Battery cut-off

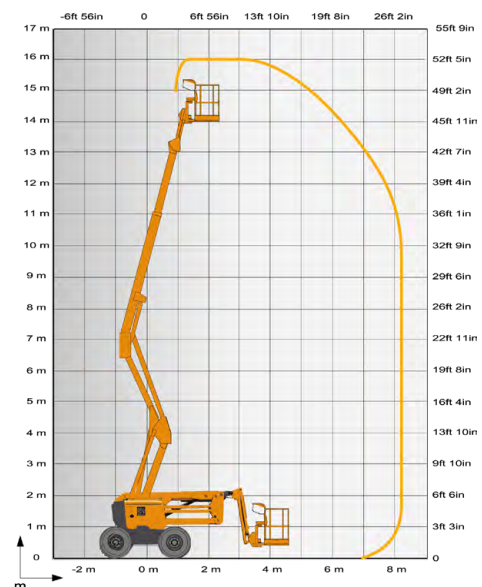

AJ Access Platforms Ltd

Pill Way, Severn Bridge Industrial Estate, Caldicot Monmouthshire, NP26 5PU, United Kingdom.
Phone: +44 (0) 1291 421 155 Email: info@accessplatforms.com, sales@accessplatforms.com



Haulotte
LET'S DARE TOGETHER