

SJ12/16

VERTICAL MASTS



STANDARD FEATURES

- Drivable at full height
- Relay based control system
- Standard Skyjack colour coded and numbered wiring
- Shroud style, impact resistant composite control box
- Proportional controls for drive and lift functions
- Tilt alarm (3.0° x 1.5°) with drive and lift cut-out
- Lift up chassis centre cover for easy access
- 24V DC Power with low voltage battery protection
- Universal smart charger
- Variable speed, front two wheel hydraulic drive
- Solid rubber, non-marking tyres
- 30% Gradeability
- Dual SAHR holding brakes
- 0.41 m Traversing platform
- Full height spring hinged entry gate
- Lanyard attachment points
- Wiring for AC outlet at platform
- Pothole protection system
- Forklift points and lift ring / tie downs
- Single point emergency lowering
- Operator horn
- Telematics ready

OPTIONS

- Light duty pipe rack
- Tool tray
- Fluorescent tube carrier
- All motion audible alarm
- Dual flashing lights
- AGM Batteries (140Ah)
- Saloon gate
- Bio oil
- 12.5 m/s Wind rating to 3.65 m (SJ16 only)
- Secondary Guarding Lift Enable (SGLE)
- ELEVATE telematics
- ELEVATE Battery Management System (BMS)*

† Standard lead times may be increased when optional equipment is added, consult factory.

‡ Capacities and machine weights may differ when options are added.

* Only available with ELEVATE telematics

SJ12/16 VERTICAL MASTS

Dimensions	SJ12	SJ16
A Work Height	5.65 m	6.75 m
B Raised Platform Height	3.65 m	4.75 m
C Lowered Platform Height	0.46 m	0.46 m
D Overall Width	0.78 m	0.78 m
E Overall Length	1.40 m	1.40 m
F Stowed Height	1.78 m	1.78 m
G Platform Width (Inside Dimension)	0.69 m	0.69 m
H Platform Length (Inside Dimension)	0.86 m	0.86 m
Specifications	SJ12	SJ16
Traversing Platform (Roll Out)	0.41 m	0.41 m
Ground Clearance (Pothole Raised)	5.3 cm	5.3 cm
Ground Clearance (Pothole Deployed)	1.3 cm	1.3 cm
Wheelbase	1.07 m	1.07 m
Weight	863 kg	980 kg
Gradeability	30%	30%
Turning Radius (Inside)	0	0
Turning Radius (Outside)	1.40 m	1.40 m
Lift Time (With Rated Load)	14 sec	21 sec
Lower time (With Rated Load)	15 sec	18 sec
Drive Speed (Stowed)	4.0 km/h	4.0 km/h
Drive Speed (Raised)	0.8 km/h	0.8 km/h
Maximum Drive Height	Full Height	Full Height
Capacity (Overall)	227 kg	227 kg
Local Floor Load (With Rated Load)	745 kN/m ²	880 kN/m ²
Overall Floor Load (With Rated Load)	1,040 kg/m ²	1,152 kg/m ²
Maximum # of Persons at 0 m/s wind rating	2	1
Maximum # of Persons up to 12.5 m/s wind rating	1	0 / Optional 1
Tyre Type	Solid, N/M	Solid, N/M
Tyre Size	12 x 4 x 8	12 x 4 x 8

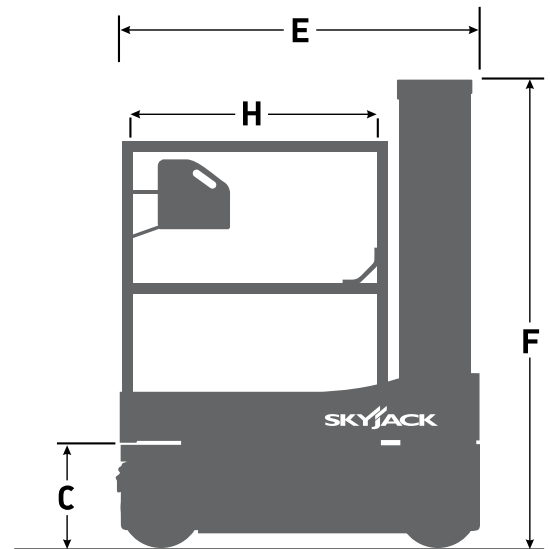
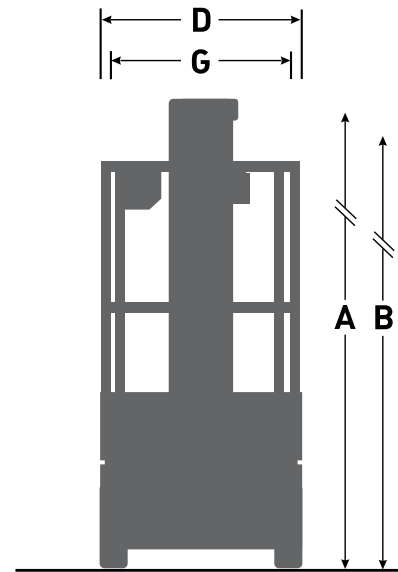

AJ Access Platforms Ltd

Pill Way, Severn Bridge Industrial Estate,
Caldicot Monmouthshire, NP26 5PU, UK
Phone: +44 (0) 1291 421 155

Email: info@accessplatforms.com, sales@accessplatforms.com

Web: www.accessplatforms.com

