

ES2632

ELECTRIC SCISSOR LIFT

SCISSOR LIFT



KEY SPECS

Platform Height

Indoor: 25-ft 5-in / 7.8-m
Outdoor: 21-ft / 6.4-m

Platform Capacity

Indoor: 507-lb / 230-kg
Outdoor: 275-lb / 125-kg

Number of Occupants

Indoor: 2
Outdoor: 1

Stowed Drive Speed

2.75 mph / 4.4 km/h

KEY FEATURES

- Available with CleanGuard leak containment system, allowing for work on sensitive flooring.
- Delivers narrow width to fit through most standard doorways and tight aisles.
- Reduce operating costs with electric drive and integrated components containing reduced hydraulic hoses and hydraulic fittings on the entire machine. Meaning, increased uptime as well as fewer leaks and service calls.
- Run longer on a single charge with double the battery life.

ACCESSORIES & OPTIONS

- 4 x 6V AGM Batteries, 220 ah
- 900W Inverter
- Anti-Vandalism PKG
- CleanGuard
- ClearSky™
- Coiled Platform Control Box Cable
- Drive Motor Covers
- Dual Flashing Amber Beacons - LED
- Eagle Performance Charger
- Flashing Amber Beacon - LED
- JLG® Mobile Control
- MDI (Ground)
- Panel Carrier
- Pipe Racks
- QuikAccess Platform
- SkySense®
- White Noise Alarm

STANDARD SPECIFICATIONS

Performance	Indoor	Outdoor
Platform Height (Elevated)	25-ft 5-in / 7.8-m	21-ft / 6.4-m
Platform Capacity	507-lb / 230-kg	275-lb / 125-kg
Capacity on Platform Extension	265-lb / 120-kg	265-lb / 120-kg
Number of Occupants	2	1
Lift / Lower Time (No Load)	33/36 seconds	33/36 seconds
Lift / Lower Time (Rated Load)	39/29 seconds	39/29 seconds
Maximum Drive Height	21-ft / 6.4-m	21-ft / 6.4-m
Weight*	4,400-lb / 1,996-kg	4,400-lb / 1,996-kg
Max. Ground Bearing Pressure	107 psi / 7.5 kg/cm ²	107 psi / 7.5 kg/cm ²
Drive Speed (Elevated)	2.75 mph / 4.4 km/h	2.75 mph / 4.4 km/h
Drive Speed (Lowered)	0.5 mph / 0.8 km/h	0.5 mph / 0.8 km/h
Gradeability	25%	25%
Max Tilt Rating (Side-to-Side)	1.5 Degrees	1.5 Degrees
Max Tilt Rating (Fore and Aft)	3.5 Degrees	3.5 Degrees
Turning Radius (Inside)	Zero	Zero
Turning Radius (Outside)	88.2-in / 2.24-m	88.2-in / 2.24-m

*Certain options or country standards increase weight

Power

Batteries	4 x 6V 220 amp-hr
Charger	27 Amp
Drive	24V DC

Tires

Standard	16 x 5-in / 406 x 125-mm
----------	--------------------------

Brakes

Multi-Disc Friction

Hydraulic System

Capacity	3.2 gal / 12 L
Pump	Fixed Displacement Gear

STANDARD FEATURES

- 27 amp Multi-Function Universal Charger
- AC Receptacle in Platform
- Active Pothole Protection System
- All Motion Alarm
- Analyzer Port for Diagnostics
- Battery Condition Indicator
- CAN-Enabled Charger
- Diamond Tread Steel Deck
- Dynamic Braking
- Electric Drive
- Foot-Actuated Deck Extension
- Fork Lift Pockets
- Greaseless Kingpin Joints
- Horn
- Hourmeter
- Lanyard Attach Points
- Lifting and Tie Down Points
- Load Sensing System
- Lubrication Free Scissor Arm Bushings
- Manual Descent Cable
- Movable, Removable Platform Control
- Nickel Plated Pins
- Proportional Controls
- QuikFold Rails
- Removable Ladder
- Scissor Maintenance Prop
- Self-Closing Gate
- Steel Swing-Out Doors
- Tilt Alarm and Light
- USB Charger & Phone Holder
- Variable Tilt Visual Zone Indicator

ES2632

ELECTRIC SCISSOR LIFT

SCISSOR LIFT



DIMENSIONS

All dimensions are approximate

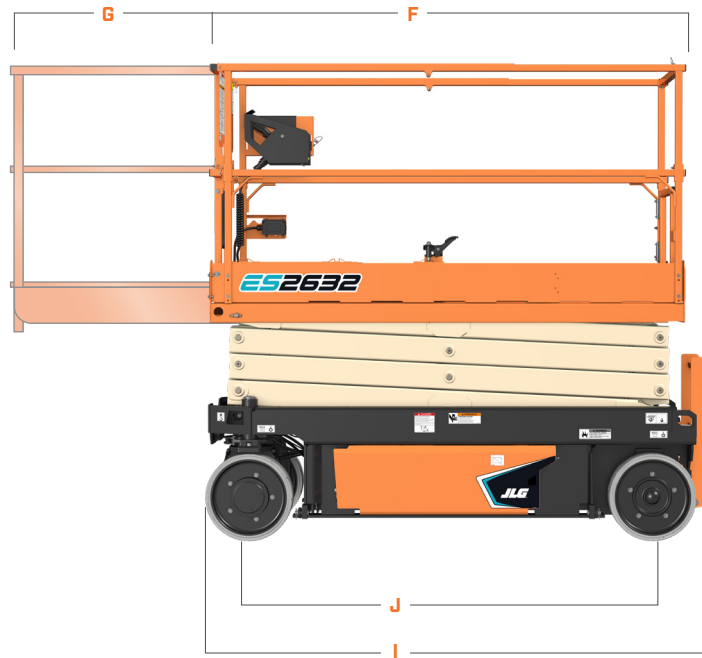
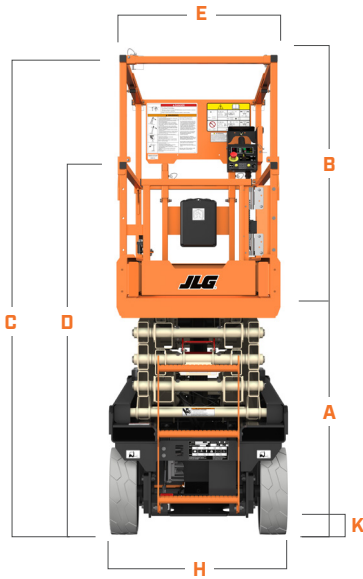

A. Platform Height (Lowered)	43.6-in / 1.1-m	H. Machine Width	32-in / 81-cm
B. Platform Railing Height	44.6-in / 1.13-m	I. Machine Length	94.3-in / 2.4-m
C. Machine Height (Rails Raised)	88.2-in / 2.2-m	J. Wheelbase	74-in / 1.9-m
D. Machine Height (Rails Lowered)	70.3-in / 1.8-m	K. Ground Clearance	3.9-in / 9.8-cm
E. Platform Width	25.4-in / .7-m		
F. Platform Length	84-in / 2.1-m		
G. Platform Extension	34-in / 86.5-cm		



AJ Access Platforms Ltd

Pill Way, Severn Bridge Industrial Estate, Caldicot Monmouthshire, NP26 5PU, United Kingdom.
Phone: +44 (0) 1291 421 155 Email: info@accessplatforms.com, sales@accessplatforms.com



We provide coverage for one (1) full year, and cover all specified major structural components for five (5) years. Due to continuous product improvements, we reserve the right to make specification and/or equipment changes without prior notification. This machine meets or exceeds applicable ANSI and CSA requirements based on machine configuration as originally manufactured for intended applications. Please reference the serial number plate on the machine for additional information.



JLG INDUSTRIES, INC.
Toll-free US 877-JLG-LIFT
JLG.com

An Oshkosh Corporation Company