

ZOOMLION ARTICULATING BOOM LIFTS

ZA20J (ZA60J)

Comply with CE/ANSI/CSA Standard

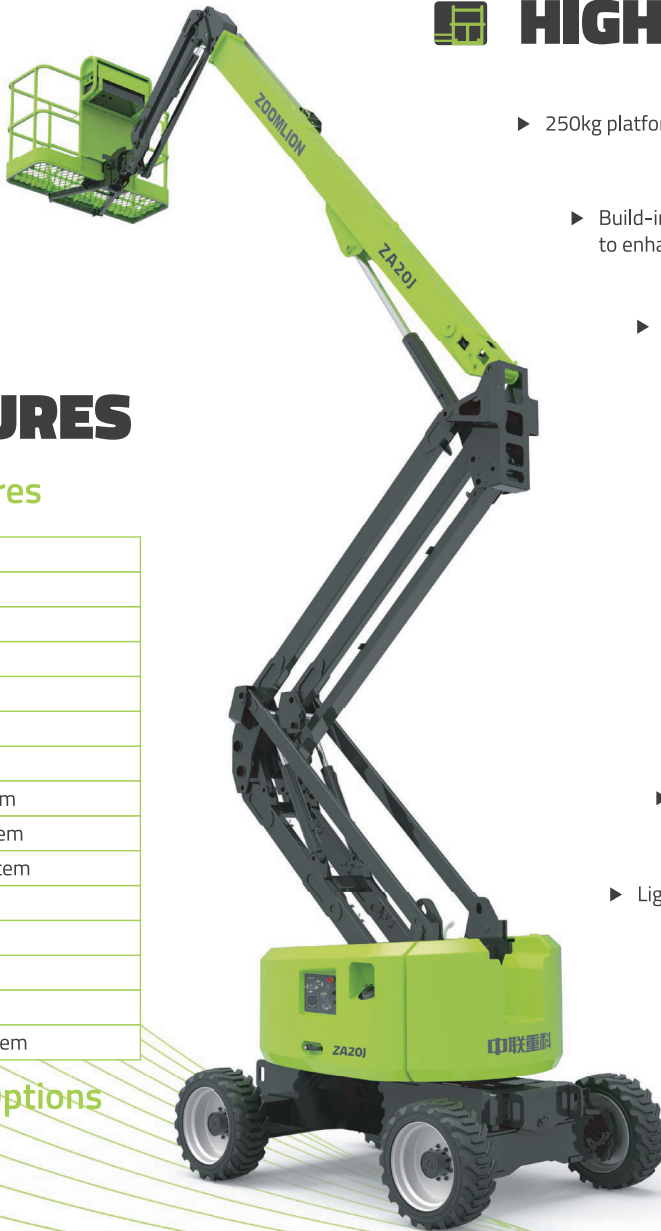

FEATURES

Standard Features

Horn
All motion alarm
Proportional control
Self-closing entry gate
Flashing amber beacon
Auto-leveling system
Emergency stop button
Over tilt protection system
Emergency descent system
On-board diagnostic system
Oscillating axle
4.3' LED display
Load sensing system
Swing-out engine tray
Secondary Guarding System

Accessories & Options

- ▶ Platform work lights
- ▶ AC power to platform
- ▶ Air line to platform
- ▶ Engine heater
- ▶ Low-temperature hydraulic oil

HIGHLIGHTS

- ▶ 250kg platform capacity for higher efficiency
- ▶ Build-in multiple pressure control leveling system to enhance stability
- ▶ Precise load sensing system to improve overload safety operations
- ▶ Integrated with rotary reducer to enhance rotation stability
- ▶ Hostile Kits available for dusty working environment
- ▶ Deadweight Lowering System for smooth operation and energy efficiency
- ▶ Platform fast lifting function provides high-efficient performance without tower boom operation
- ▶ Lightweight design, low energy consumption

ACCESS WITH ZOOMLION GREEN

Phone: 0086(731)-88353680 0086(731)-88250971
E-mail: awm@zoomlion.com

Add: ZOOMLION Wangcheng Industrial Park, Tengfei Road 997, Changsha, Hunan, China
Web: www.en.zoomlion.com



MAIN SPECS OF ARTICULATING BOOM LIFTS

ZA20J (ZA60J)

Comply with CE/ANSI/CSA Standard

Model	ZA20J (ZA60J)	
	Imperial	Metric
Size		
Work Height	70ft 2in	21.38m
Platform Height	63ft 7in	19.38m
Horizontal Outreach	40ft 4in	12.3m
Up and Over Height	27ft 1in	8.25m
A - Stowed Length	28ft 11in	8.82m
B - Stowed Width	8ft 1in	2.46m
C - Stowed Height	8ft 4in	2.52m
D - Platform Length	8/6ft	2.44/1.83m
E - Platform Width	3ft/2ft 6in	0.91/0.76m
Jib Length	5ft	1.53m
F - Wheelbase	8ft 3in	2.52m
G - Ground Clearance	1ft 5in	0.42m
Performance		
Platform Capacity	550 lb	250kg
Drive Speed	3.79 mph	6.1km/h
Gradeability	45%(24°)	
Axles Oscillation	8in	0.2m
Turning Radius (Inside)	8ft 3in	2.51m
Turning Radius (Outside)	17ft 11in	5.47m
Turntable Swing	360° continuous	
Platform Rotation	±90°	
H-Tail Swing	1ft 4in	0.4m
Max. Wind Speed	28mph	12.5m/s
Power		
Diesel Engine	Kubota V2403 36kW/2600rpm Weichai WP3.2G50E3 17A 36.8kW/2500rpm	
Fuel Tank Capacity	39.6 (us gal)	150L
Auxiliary Power	12V	
Control Voltage	12V	
Hydraulic System Capacity	42.3 (us gal)	160L
Hydraulic Tank Capacity	19.8 (us gal)	75L
Tire		
Type	33×12/D610 Foam-filled Tires	
Weight		
Gross	22046 lb	10000kg

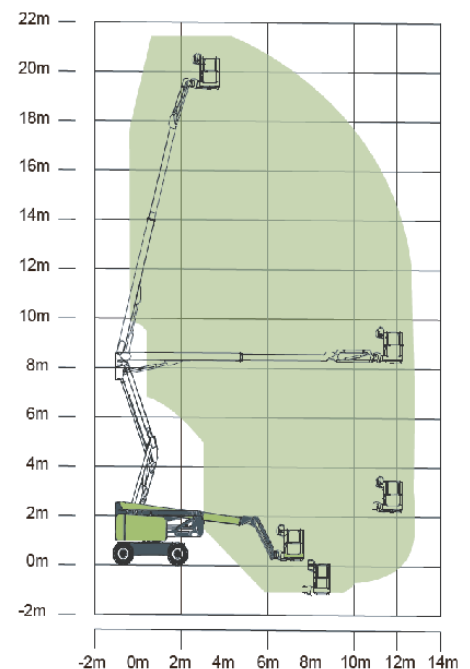
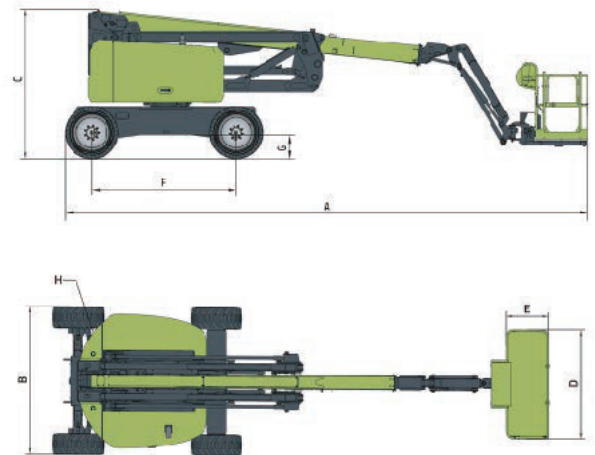

Range of Motion ZA20J