

# ZOOMLION ARTICULATING BOOM LIFTS

## ZA24J (ZA80J)

Comply with CE Standard



### HIGHLIGHTS



▶ 550lb/250kg platform capacity for higher efficiency

▶ Build-in multiple pressure control system to enhance stability

▶ Precise load sensing system to improve overload safety operations

▶ Platform fast lifting function provides high-efficient performance without tower boom operation



### FEATURES

#### Standard Features

Horn
All motion alarm
Proportional control
Self-closing entry gate
Flashing amber beacon
Auto-leveling system
Emergency stop button
Over tilt protection system
Emergency descent system
On-board diagnostic system
Oscillating axle
4.3' LED display
Load sensing system
Swing-out engine tray
Secondary Guarding System

▶ Hostile Kits available for dusty working environment

▶ Outstanding below ground reach of 5.1m

▶ 86ft 11in/26.50m working height

#### Accessories & Options

- ▶ Platform work lights
- ▶ AC power to platform
- ▶ Air line to platform
- ▶ Engine heater
- ▶ Low-temperature hydraulic oil

## ACCESS WITH ZOOMLION GREEN

Phone: 0086(731)-88353680 0086(731)-88250971  
E-mail: awm@zoomlion.com

Add: ZOOMLION Wangcheng Industrial Park, Tengfei Road 997, Changsha, Hunan, China  
Web: www.en.zoomlion.com



# MAIN SPECS OF ARTICULATING BOOM LIFTS

## ZA24J (ZA80J)

Comply with CE Standard

Model	ZA24J (ZA80J)	
	Imperial	Metric
<b>Size</b>		
Work Height	86ft 11in	26.5m
Platform Height	80ft 5in	24.5m
Horizontal Outreach	62ft	18.9m
Up and Over Height	30ft 11in	9.42m
A - Stowed Length	36ft 11in	11.25m
B - Stowed Width	8ft 2in	2.49m
C - Stowed Height	9ft 10in	3.0m
D - Platform Length	8ft	2.44m
E - Platform Width	2ft 12in	0.91m
Jib Length	6ft	1.83m
F - Wheelbase	10ft	3.05m
G - Ground Clearance	1ft 4in	0.4m
<b>Performance</b>		
Platform Capacity	550 lb	250kg
Drive Speed	3.11 mph	5.0km/h
Gradeability	45%(24°)	45%(24°)
Axles Oscillation	8in	0.2m
Turning Radius (Inside)	10ft 12in	3.35m
Turning Radius (Outside)	21ft 3in	6.48m
Swing	360° continuous	
Platform Rotation	±90°	
H-Tail Swing	3ft 1in	0.94m
Max. Wind Speed	28mph	12.5m/s
<b>Power</b>		
Diesel Engine	Cummins QSF2.8 54kW/2400rpm	
Fuel Tank Capacity	39.6 (us gal)	150L
Auxiliary Power	12V	
Control Voltage	12V	
Hydraulic System Capacity	63.4 (us gal)	240L
Hydraulic Tank Capacity	47.6 (us gal)	180L
Drive	4WD	
<b>Tire</b>		
Type	15-625 Foam-filled Tires	
<b>Weight</b>		
Gross	40344 lb	18300kg

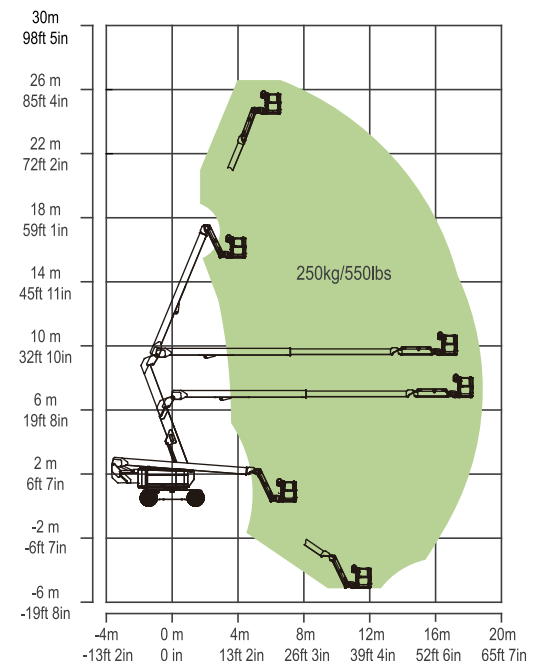
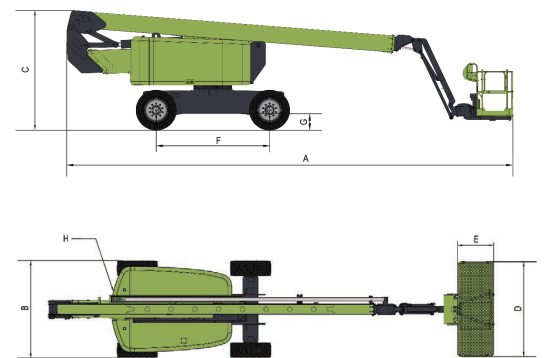

Range of Motion ZA24J