

ZOOMLION TELESCOPIC BOOM LIFT ZT26J (ZT88J)

Comply with CE/ANSI/CSA Standard

HIGHLIGHTS



- ▶ Better work envelop performance, 10% larger than competitor
- ▶ Industry leading telematic control interface with self-diagnostic monitoring capability
- ▶ Smooth & stable boom extension control as low as 15mm/s (0.034mph)
- ▶ Dual lift capacity of 300kg(660-lb) unrestricted and 454kg (1,000-lb) restricted.

FEATURES

Standard Features

Horn
Proportional control
All motion alarm
Flashing beacon
Self-closing entry gate
Emergency descent system
Emergency stop button
Auto-leveling system
On-board diagnostic system
Tilt protection system
Oscillating axle
Load sensing system
4.3' Led display
Swing-out engine tray

Accessories & Options

- ▶ Platform work light
- ▶ Anti-collision device
- ▶ AC power to platform

ACCESS WITH ZOOMLION GREEN

Phone: 0086(731)-88353680 0086(731)-88250971
E-mail: awm@zoomlion.com

Add: ZOOMLION Wangcheng Industrial Park, Tengfei Road 997, Changsha, Hunan, China
Web: www.en.zoomlion.com



MAIN SPECS OF TELESCOPIC BOOM LIFT

ZT26J (ZT88J)

Comply with CE/ANSI/CSA Standard

Model	ZT26J (ZT88J)	
	Imperial	Metric
Size		
Work Height	92ft 6in	28.20m
Platform Height	85ft 11in	26.20m
Horizontal Outreach	76ft 6in	23.31m
A - Stowed Length	41ft	12.50m
B - Stowed Width	8ft 2in	2.49m
C - Stowed Height	9ft 2in	2.80m
D - Platform Length	8ft	2.44m
E - Platform Width	3ft	0.91m
F - Wheelbase	10ft	3.05m
Tread	8ft 2in	2.49m
G - Ground Clearance	1ft 4in	0.41m
Performance		
Platform Capacity (Unrestricted/Restricted)	660/1000lb	300/454kg
Drive Speed (Stowed)	3.42mph	5.5km/h
Gradeability	45% (24°)	45% (24°)
Turning Radius (Inside)	11ft 10in	3.6m
Turning Radius (Outside)	22ft 4in	6.8m
Turntable Swing	360° continuous	
Platform Rotation	±90°	
Tail Swing	5ft 3in	1.60m
Jib (Range of Articulation)	130° (-55° ~ 75°)	
Max. Wind Speed	28mph	12.5m/s
Power		
Engine	Cummins QSF2.8 (GB) 54kW/2400rpm Kubota V2607 (EU) 55.4kW /2700rpm TD 2.9 L4 (EU IIIB, US T4) 50kW/2600rpm	
Fuel Tank Capacity	39.6 (us gal)	150L
Control Voltage	12V DC	
Hydraulic Tank Capacity	39.6 (us gal)	150L
Drive Mode	4WD	
Steering Mode	Front-wheel	
Tire		
Type	385/65-24 Solid Tires	
Weight		
Gross	41667lb	18900kg

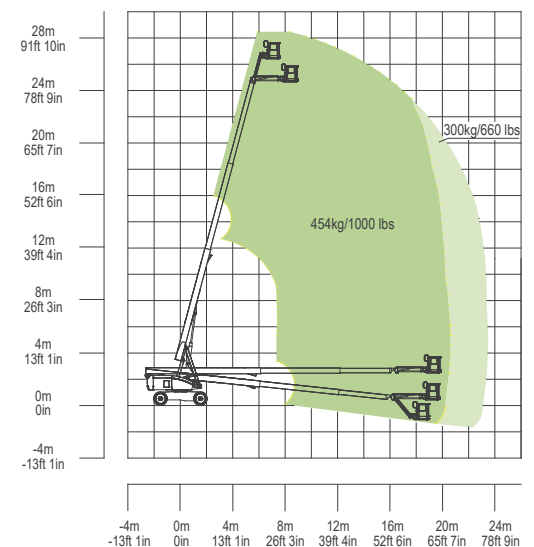
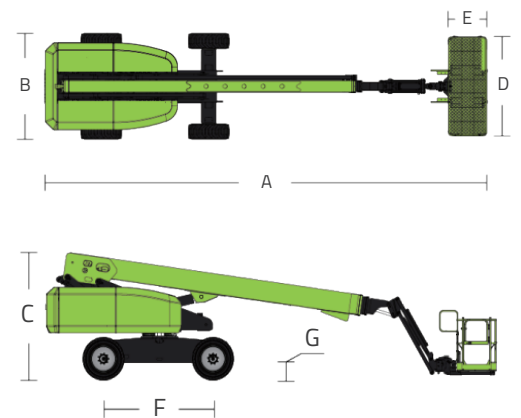

Range of Motion ZT26J (ZT88J)