

ZOOMLION

**NEW**

**ROUGH TERRAIN**

ELECTRIC ARTICULATING BOOM LIFTS

**ZA16JERT**

Comply with CE/ANSI Standard

## HIGHLIGHTS

- ▶ Center layout, great structural rigidity, and small boom deflection
- ▶ Accurate and efficient traveling AC drive system provides strong power and stable control, motor maintenance-free
- ▶ Electrical off-road articulating boom lift of 16m height with strong power suits for complicated working conditions
- ▶ 4WD provides strong power, ideal for off-road application
- ▶ Advanced dual control system (valve control + pump control) offers a energy-saving, smooth and efficient control
- ▶ Large-capacity lithium battery features long-lasting battery life, and number of charge and discharge cycles reaches 2500 times, the whole life cycle is maintenance-free, and a 5-year warranty is provided (ZA16JERT-Li Only)

## FEATURES

### Standard Features

- Proportional control
- All motion alarm
- Flashing beacon
- Self-closing entry gate
- Emergency descent system
- Emergency stop button
- Auto-leveling system
- On-board diagnostic system
- Over tilt protection system
- Oscillating axle
- Load sensing system
- Battery management system (ZA16JERT-Li Only)
- 4.3" LED display
- Horn
- Anti-crushing device
- Fast charging (ZA16JERT-Li Only)

### Accessories & Options

- Platform light
- AC power to platform
- Airline to platform
- Non-marking tire
- Fast charging (ZA16JERT Only)

**ACCESS WITH ZOOMLION GREEN**

Phone: 0086(731)-88253680 0086(731)-88253973  
E-mail: awp@zoomlion.com

Add: 701 Xulong Nan Lu, Xiangjiang New District, Changsha Hunan, China  
Web: www.zoomlion-access.com



**ZOOMLION**

# ROUGH TERRAIN ELECTRIC ARTICULATING BOOM LIFTS

**NEW** ROUGH TERRAIN

**ZA16JERT** Comply with CE/ANSI Standard

Model	ZA16JERT		ZA16JERT-Li	
	Imperial	Metric	Imperial	Metric
<b>Size</b>				
Work Height	58ft 5in	17.8m	58ft 5in	17.8m
Platform Height	51ft 10in	15.8m	51ft 10in	15.8m
Horizontal Outreach	31ft 11in	9.72m	31ft 11in	9.72m
Up and Over Height	26ft 3in	8m	26ft 3in	8m
A - Stowed Length	25ft 3in	7.7m	25ft 3in	7.7m
B - Stowed Width	7ft 6in	2.3m	7ft 6in	2.3m
C - Stowed Height	7ft 4in	2.23m	7ft 4in	2.23m
D - Platform Length	6ft	1.83m	6ft	1.83m
E - Platform Width	2ft 6in	0.76m	2ft 6in	0.76m
F - Wheelbase	7ft 9in	2.36m	7ft 9in	2.36m
G - Ground Clearance	1ft 2in	0.36m	1ft 2in	0.36m
<b>Performance</b>				
Platform Capacity	550 lb	250kg	550 lb	250kg
Drive Speed	3.4 mph	5.5km/h	3.4 mph	5.5 km/h
Gradeability	45%(24°)		45%(24°)	
Axles Oscillation	8in	0.20m	8in	0.20m
Turning Radius (Inside)	6ft 9in	2.06m	6ft 9in	2.06m
Turning Radius (Outside)	15ft 8in	4.78m	15ft 8in	4.78m
Turntable Swing	360° non-continuous		360° non-continuous	
Platform Rotation	±90°		±90°	
H-Tail Swing	0.6ft	0.2m	0.6ft	0.2m
Max. Working Slope	5°		5°	
Max. Wind Speed	28mph	12.5m/s	28mph	12.5m/s
<b>Power</b>				
Battery	24×2V/320Ah		48V/315Ah Li-ion battery	
Charger	48V/35A 48V/60A		48V/60A	
Drive Motor	AC 32V		AC 32V	
Lift Motor	AC 32V		AC 32V	
Auxiliary Power	12V DC Electrical pump		12V DC Electrical pump	
Hydraulic Tank Capacity	7.9 (us gal)	30L	7.9 (us gal)	30L
<b>Tire</b>				
Type	33×12 Foam-filled tire		33×12 Foam-filled tire	
<b>Weight</b>				
Gross	16093 lb	7300 kg	16093lb	7300kg

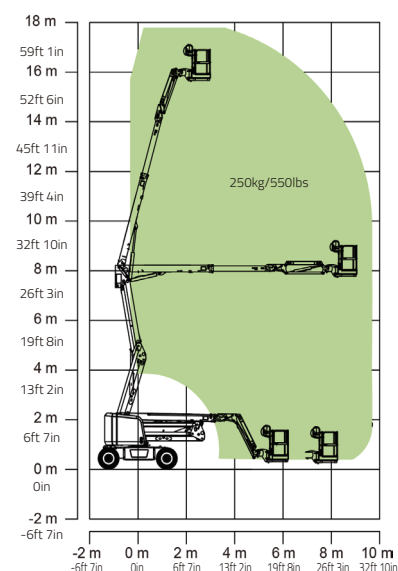
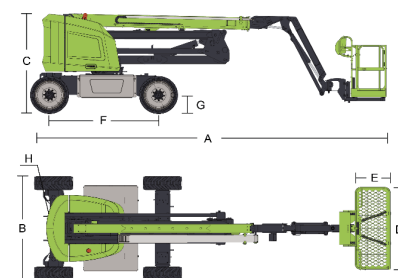

Range of Motion ZA16JERT/ZA16JERT-Li

