

ZOOMLION

ARTICULATING BOOM LIFT

ZA32J

Comply with CE Standard

FEATURES

Standard Features

Horn
All motion alarm
Proportional control
Self-closing entry gate
Flashing beacon
Auto-leveling system
Emergency stop button
Over tilt protection system
Emergency descent system
On-board diagnostic system
Oscillating axle
4.3' LED display
Load sensing system
Swing-out engine tray

Accessories & Options

- ▶ Platform work lights
- ▶ Anti-collision device
- ▶ AC power to platform

HIGHLIGHTS

- ▶ Provide heavy lifting of 250kg load for 28% higher efficiency
- ▶ Build-in multiple pressure control leveling system to enhance stability
- ▶ Precise load sensing system to improve overload safety operations
- ▶ Deadweight Lowering System for smooth operation and energy efficiency
- ▶ Outstanding below ground reach of 5.7m

ACCESS WITH ZOOMLION GREEN

Phone: 0086(731)-88353680 0086(731)-88250971
E-mail: awp@zoomlion.com

Add: 701 Xulong Nan Lu, Xiangjiang New District, Changsha Hunan, China
Web: www.zoomlion-access.com



ARTICULATING BOOM LIFT

ZA32J

Comply with CE Standard

Model	ZA32J	
	Imperial	Metric
Size		
Work Height	111ft 1in	33.85m
Platform Height	104ft 6in	31.85m
Horizontal Outreach	69ft 5in	21.17m
Up and Over Height	47ft 8in	14.52m
A - Stowed Length	41ft 4in	12.6m
B - Stowed Width	8ft 2in	2.49m
C - Stowed Height	10ft 2in	3.1m
D - Platform Length	8ft	2.44m
E - Platform Width	3ft 12in	0.91m
Jib Length	8ft	2.44m
F - Wheelbase	12ft 6in	3.81m
G - Ground Clearance	1ft 5in	0.42m
Performance		
Platform Capacity	550 lb	250kg
Drive Speed	3.23 mph	5.2km/h
Gradeability	45%	45%
Axles Oscillation	8in	0.2m
Turning Radius (Inside)	25ft 3in/10ft 10in	7.7/3.3m
Turning Radius (Outside)	35ft 5in/26ft 11in	10.8/8.2m
Swing	360° continuous	
Platform Rotation	±90°	
H-Tail Swing	0	
Max. Wind Speed	28mph	12.5m/s
Power		
Diesel Engine	Cummins QSF2.8 54kw/2400rpm Kubota V2607 55.4kw/2700rpm	
Fuel Tank Capacity	52.8 (us gal)	200L
Auxiliary Power	12V	
Control Voltage	12V	
Hydraulic System Capacity	79.3 (us gal)	300L
Hydraulic Tank Capacity	52.8 (us gal)	200L
Tire		
Type	445/50D710 Foam-filled Tires	
Weight		
Gross	42328 lb	19200kg

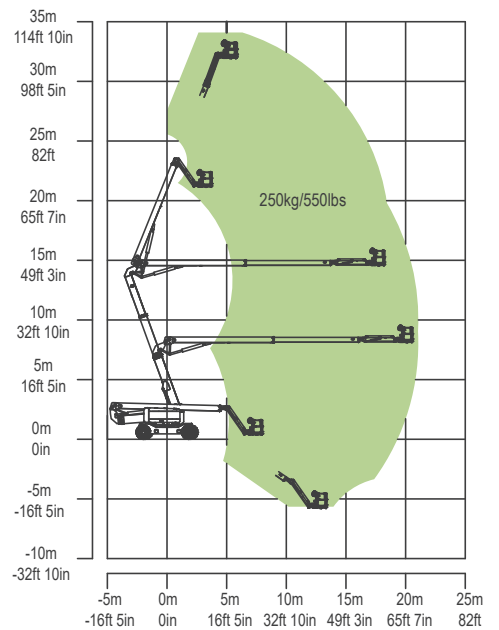
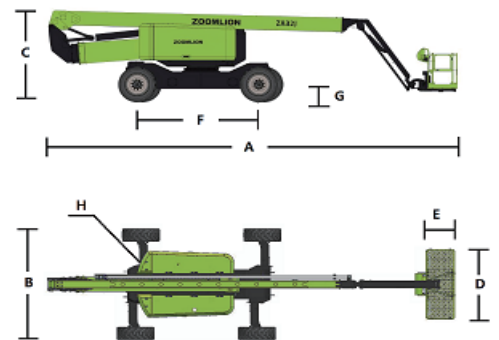

Range of Motion ZA32J